

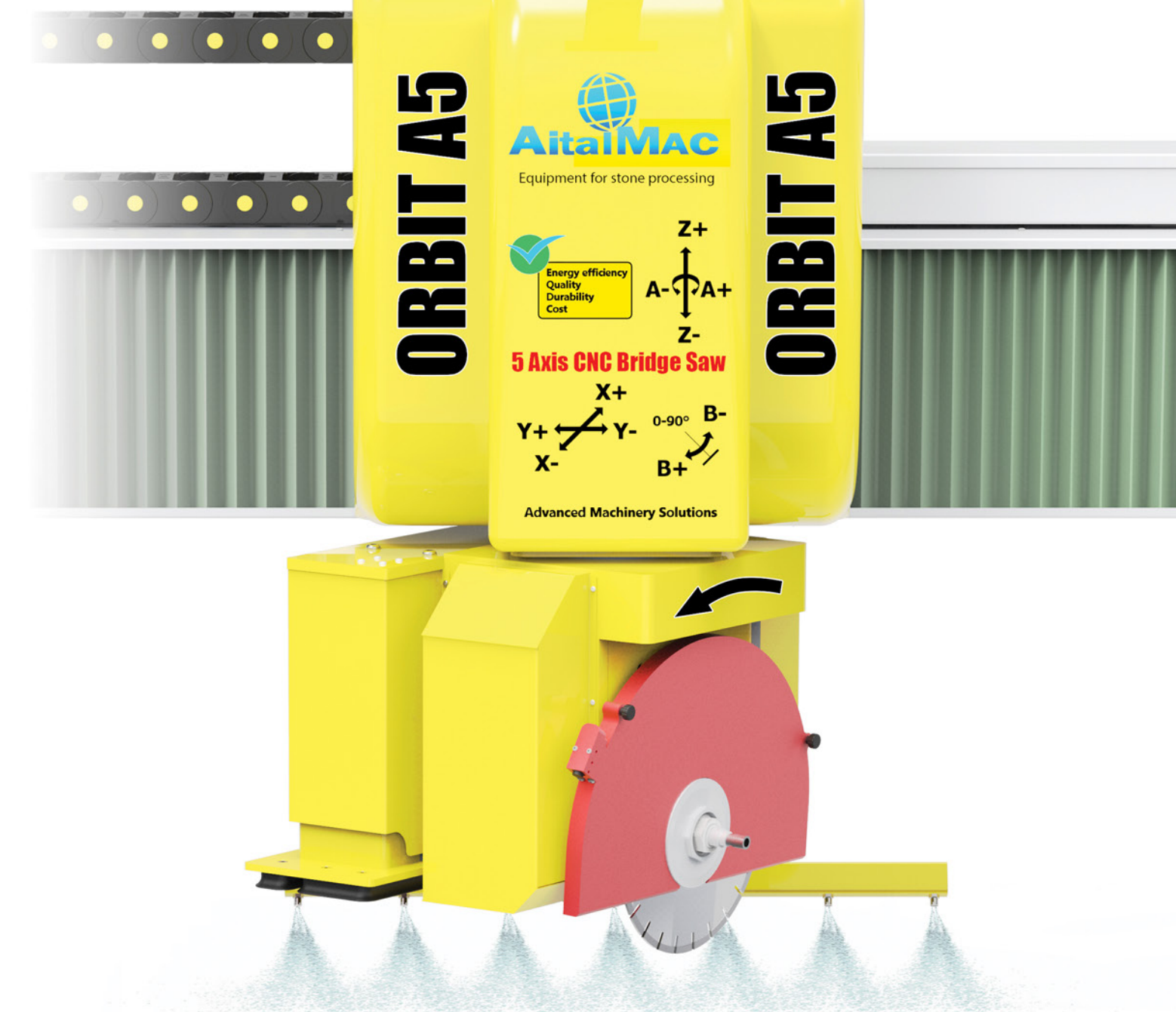

Equipment for stone processing

ORBIT A5

5 Axis CNC Bridge saw
五轴CNC桥切机



Technical data 技术参数		ORBIT A5	
Workable area (X, Y, Z, A°, B°) 加工尺寸	mm - in	3600, 2450, 380, 400°, 90°	141, 97, 15, 400°, 90°
Maximum Blade Diameter 最大锯片直径	mm - in	500 625 Optional	20 25 Optional
Overall dimensions 外形尺寸	mm - in	5850 x 4450 x 2800	230 x 175 x 110
Max cut thickness vertical 垂直切割最大厚度	mm - in	150	5.9
Cutting Disc Hole Diameter 锯片中心孔直径	mm	50	1.96
Cutting Disc Flange Diameter 锯片法兰直径	mm	180	7
Electric spindle Power 主轴电机功率	kW - Nm	11 kW (S3)	60 Nm (S3)
Max cutting and return speed 切割及往复速度范围(X, Y, Z, A&B)	m/min - ft/min	36, 36, 4, 5000°/min	118, 118, 13, 5000°/min
Air pressure 气压	bar	7	7
Total Weight 总重	kg - lbs	6500	14330
Water consumption 耗水	l/min - gal/min	15-25	4-6.5
Vacuum cups 真空吸盘	number	4	4
Vacuum lift capacity 真空吸附载重	kg - lbs	500	1100
Max. Install Power 最大安装功率	kW	16	16
Maximum spindle rotation 主轴最高转速	rpm	6000	6000

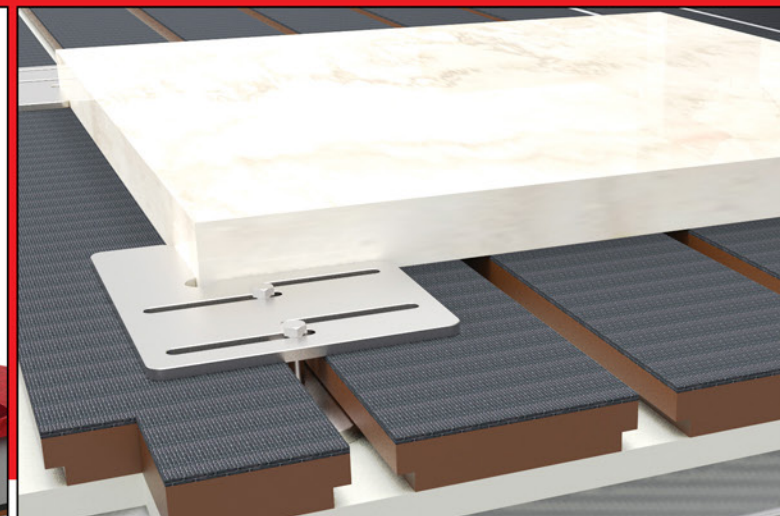
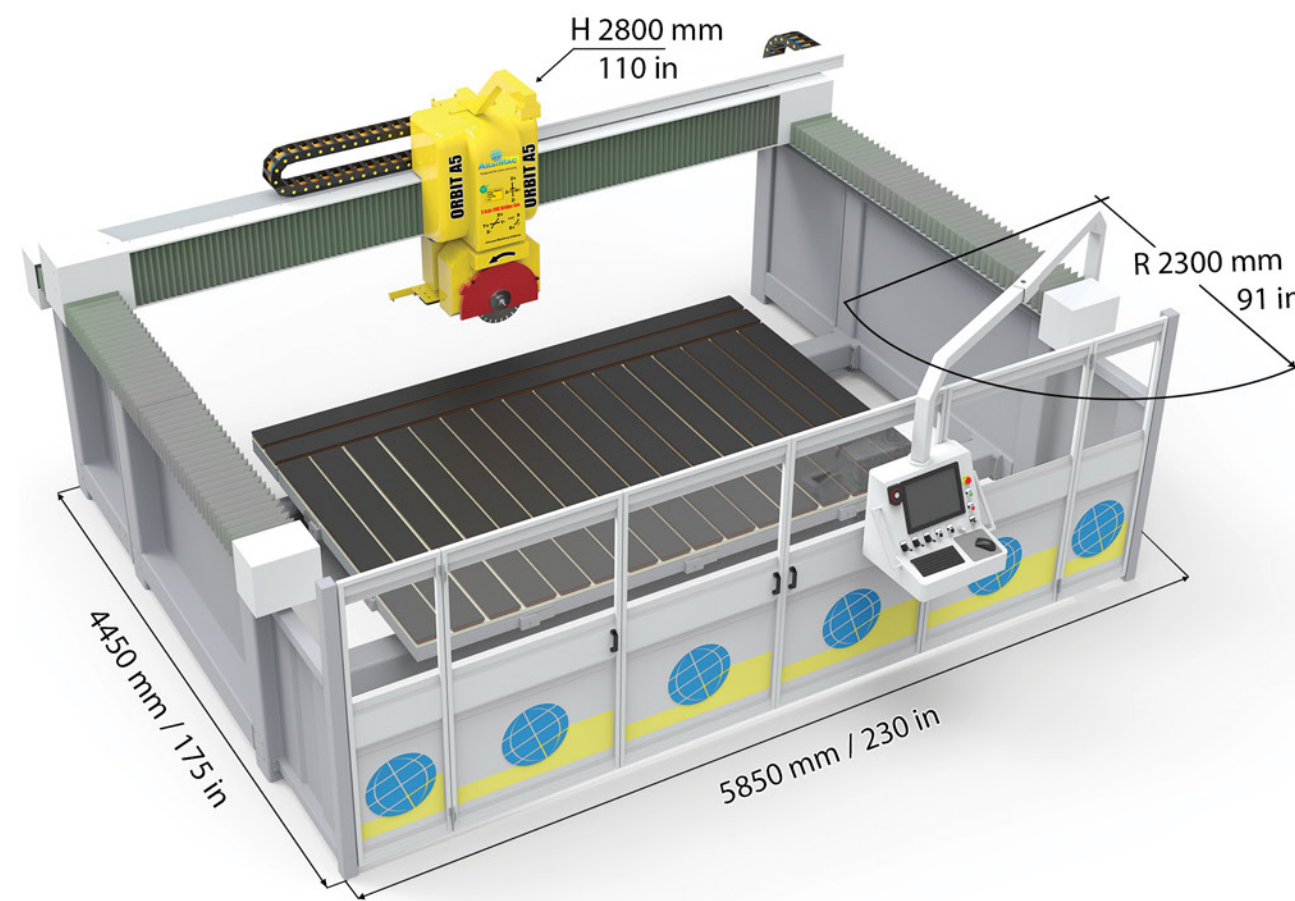

The table is made out of 3 layers of different materials. It's possible to block parts using convenient fixtures.
工作台由三层材料制成(如下图所示)。工作台上配有T型槽,并配有一套锁紧工装,可将板材锁紧在工作台上。该工装主要用于需要加工一些较小的石材,或需要针对石材做一些重型的加工工时采用。

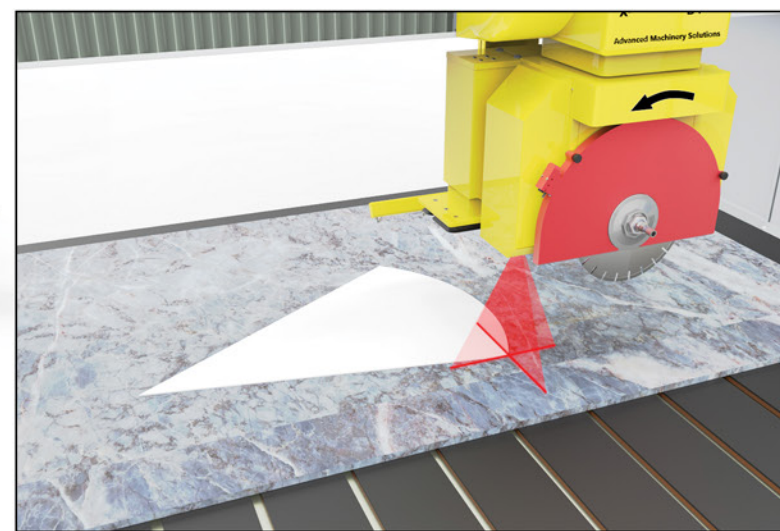

The machine is equipped with a system to digitize templates, using a laser pointer it's possible to acquire points and save them in a DXF file, that can be used in CAD.
机器上配备有一套数字模板生成系统,可以将你的木模板通过激光取点后自动在电脑里面生成DXF图形文件(CAD文件)。

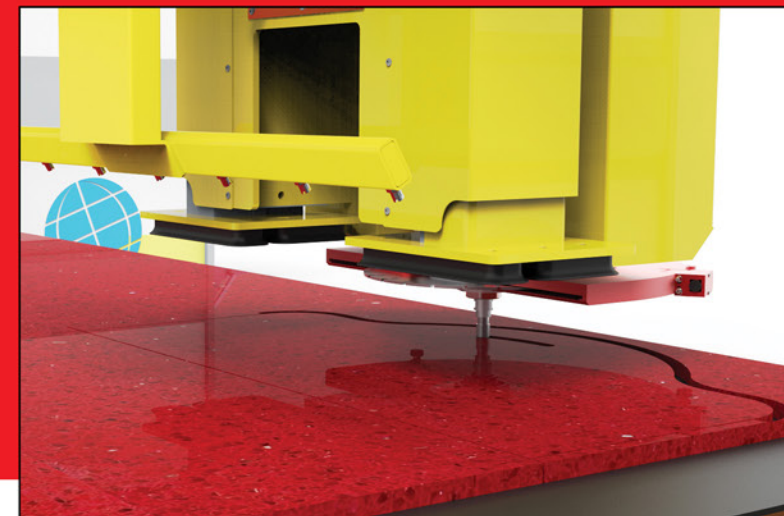
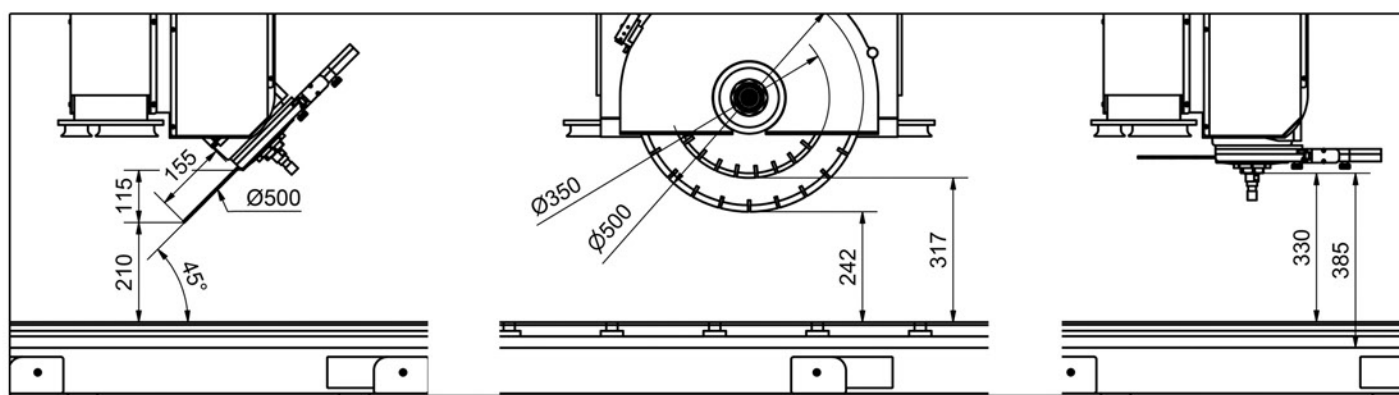

1/2" gas with internal water for: fingerbit, engraving, polishing, drain boards
1/2英寸螺纹接口带内水冷却,用于:铣刀,雕刻刀,抛光,沥水板等

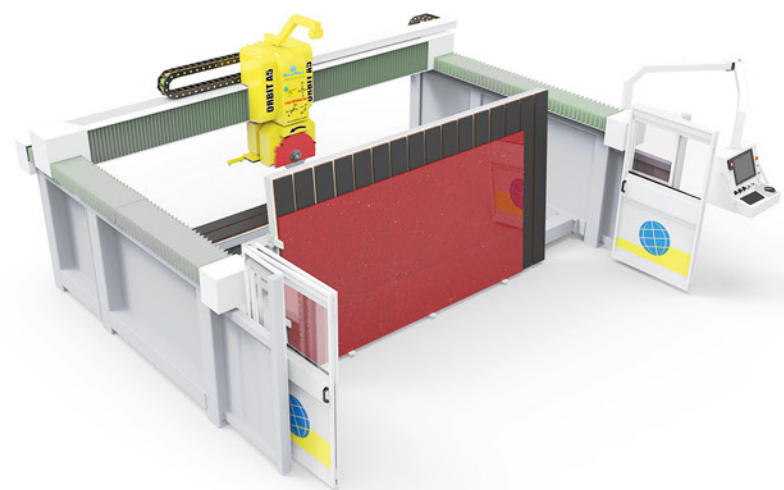

Tilting table up to 85° for easy load of the slab
工作台面通过两套液压油缸翻转至85°,方便客户上大板。



AitalMAC CO.,LTD
Tel : 0086-25-57311800 info@aitalmac.com
Fax : 0086-25-57889845 www.aitalmac.com



AitalMAC CO.,LTD
info@aitalmac.com
www.aitalmac.com

亚洲区域销售: 张丽萍
xiao@aitalmac.com
微信: xiao1257955261
QQ: 1257955261

Mr. Luca Toniolo
Luca@aitalmac.com
wechat toniolo_luca
skype toniolo_luca



AitalMAC CO.,LTD
Hengsheng road #1, Gao Chun EDZ
Nanjing, 211300, China

亚意达(南京)石材机械有限公司
地址: 南京市高淳经济开发区恒盛路1号



5 Axis CNC Bridge saw
五轴CNC桥切机

ORBIT A5

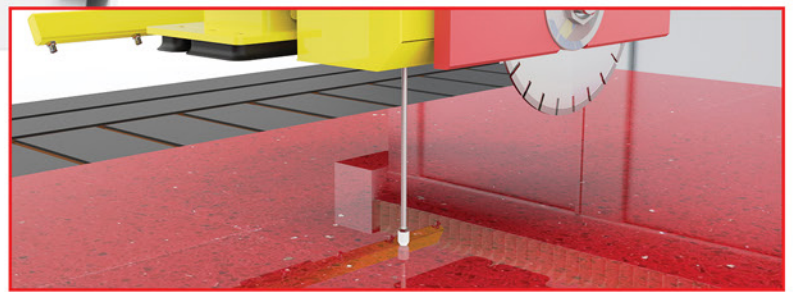
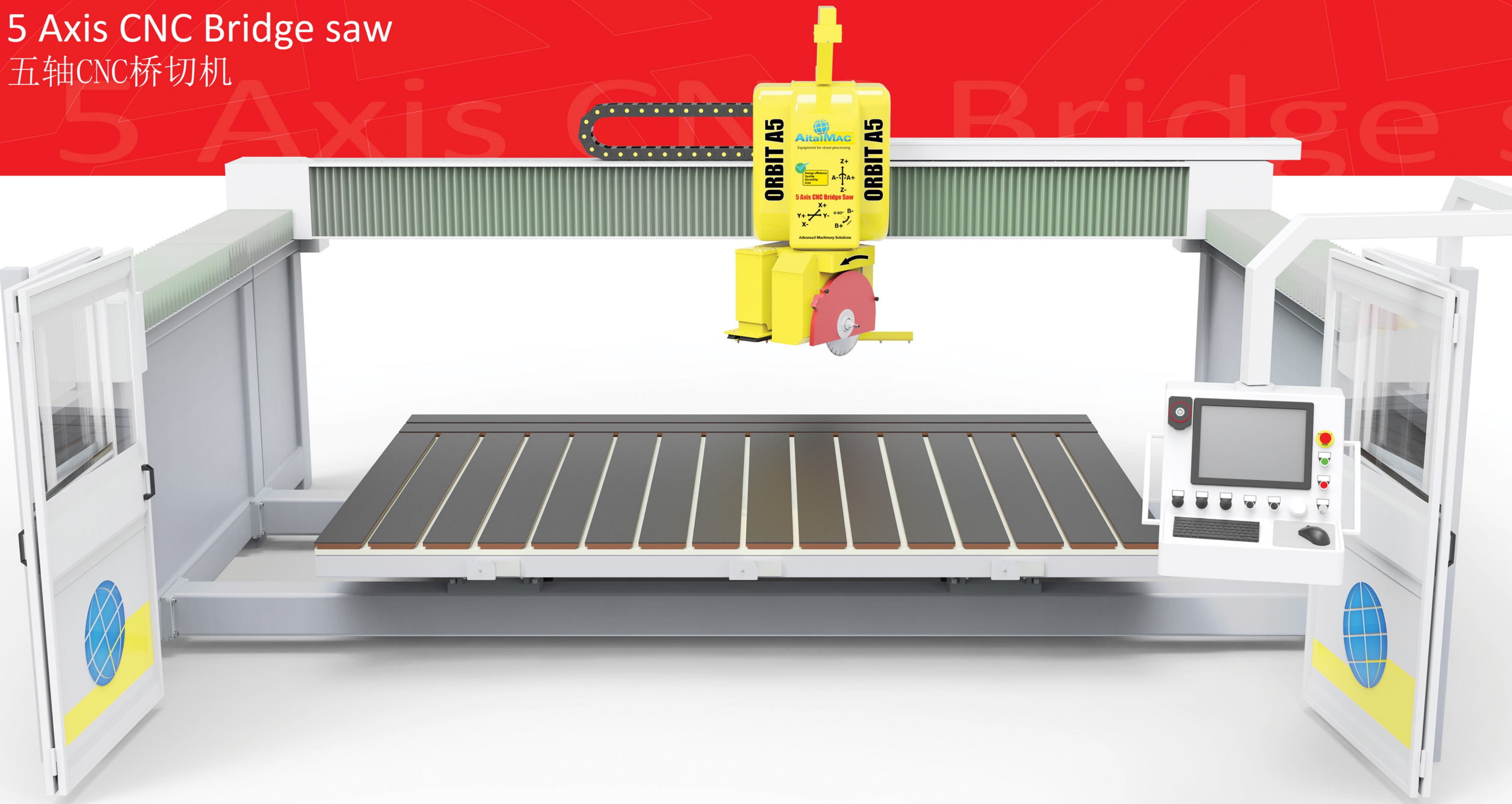

Stone probe 石材预设

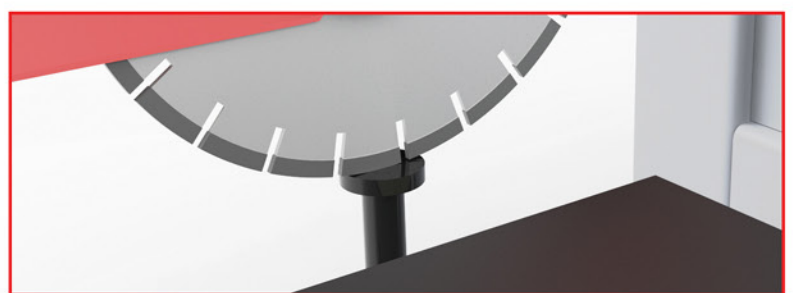

Blade probe 锯片预设

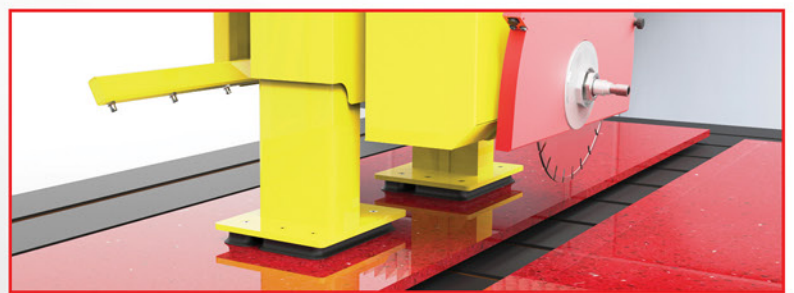

Vacuum move system 真空挪移系统



Camera on board 移动式摄像头